

Regent pumps

A U S T R A L I A

founded 1948

RSV Series

Vertical Multistage In Line Pumps

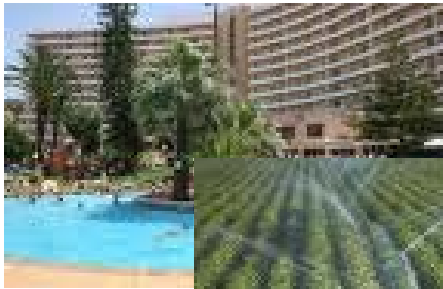

Water Supply

Industrial

Irrigation



..... all about moving fluids

RSV Series

Vertical Multistage In Line Pumps



APPLICATIONS



WATER SUPPLY

- ❑ Main water supply system for water utilities and distribution networks.
- ❑ Water pressure boosting system for multi-storey building.



INDUSTRY

- ❑ Water supply system for food industry, slaughterhouses, dairies, breweries, hotels, etc
- ❑ Pharmaceutical and metal industries where water pressure boosting is essential part of the process.
- ❑ Fire-fighting



IRRIGATION

- ❑ Irrigation for play ground, golf courses, farm, etc
- ❑ Parks and other recreational
- ❑ vineyards



Also available – Inverter Control Variable Speed Booster System Package designed to your specific need

OPERATING PARAMETERS

- ❑ Thin, clean, non-aggressive liquids which do not contain solid particles or fibres.
- ❑ Maximum Flow – 80 m³/h
- ❑ Maximum Head - 320 Metres
- ❑ Liquid Temperature – 0 to +70 °C (Higher up to 120 °C available as option)
- ❑ Minimum Inlet Pressure – In according to the NPSH Curve plus a safety margin of the minimum 0.5 Metres Head

Sectional Drawing & Materials

Item	Part Description	Material	DIN Standard
1	Motor Base	Cast Iron	GG20
2	Shaft	Stainless Steel SS304 Stainless SS316	1.4301 1.4401
3	Pump Top Casing	Cast Iron	GG20
4	Mechanical Seal	Silicon Carbide/Carbon/EPDM	
5	Impeller	Stainless Steel SS304	1.4301
6	Diffuser	Stainless Steel SS304	1.4301
7	Outer Cylinder	Stainless Steel SS304	1.4301
8	Sleeve	Stainless Steel SS304	1.4301
9	Pump Inlet / Outlet Header	Cast Iron Stainless Steel SS304	GG20 1.4301
10	Elastomer	EPDM	
11	Pump Base	Cast Iron	GG20

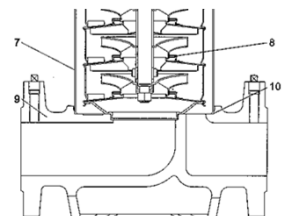

Flange Inlet/Outlet
RSV8, RSV16, RSV 32,
RSV45, RSV64, RSV90

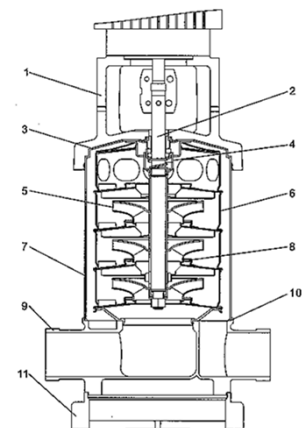

Pipe Threads Inlet/Outlet
RSV2 , RSV4

RSV Series Vertical Multistage In Line Pumps

RSV2



Performance Curve

2900 rpm

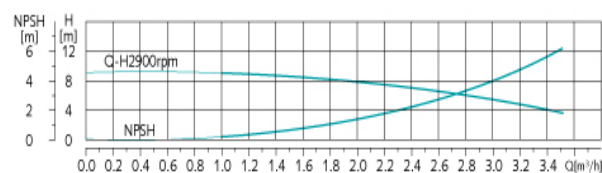
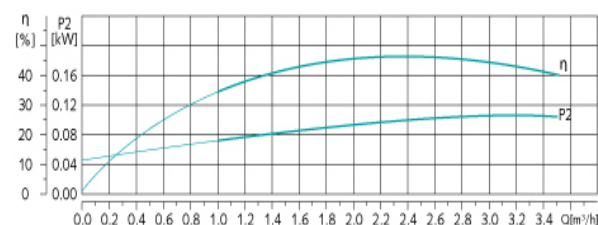
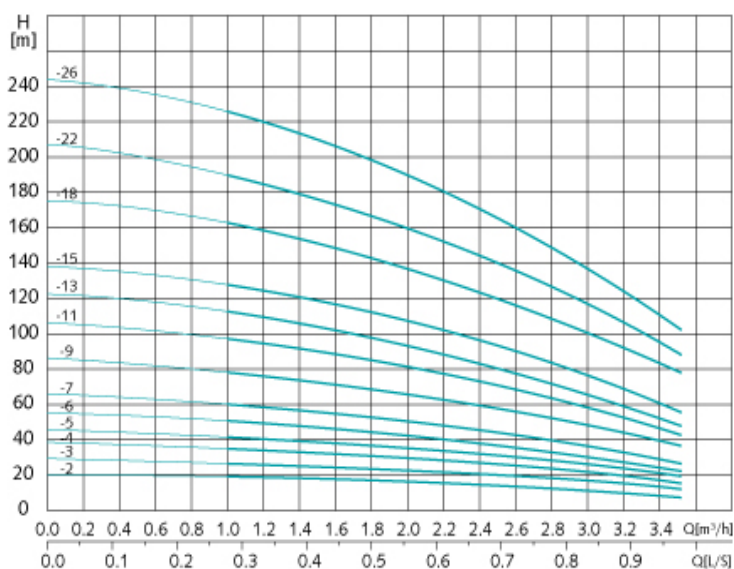

Technical Data

Model	Power (kW)	B 1	B 2	B1+B2	D1	D2	N. W. (kg)	G. W. (kg)
RSV2-2	0.37	260	220	480	145	80	27	33
RSV2-3	0.37	278	220	498	145	80	28	33
RSV2-4	0.55	296	220	516	145	80	29	34
RSV2-5	0.55	314	220	534	145	80	29	35
RSV2-6	0.75	340	255	595	175	145	32	38
RSV2-7	0.75	358	255	613	175	145	33	39
RSV2-9	1.1	394	255	649	175	145	36	42
RSV2-11	1.1	430	255	685	175	145	37	43
RSV2-13	1.5	479	265	744	195	155	41	47
RSV2-15	1.5	515	265	780	195	155	42	49
RSV2-18	2.2	569	290	859	195	155	46	53
RSV2-22	2.2	641	290	931	195	155	48	55
RSV2-26	3	722	325	1047	215	180	53	61

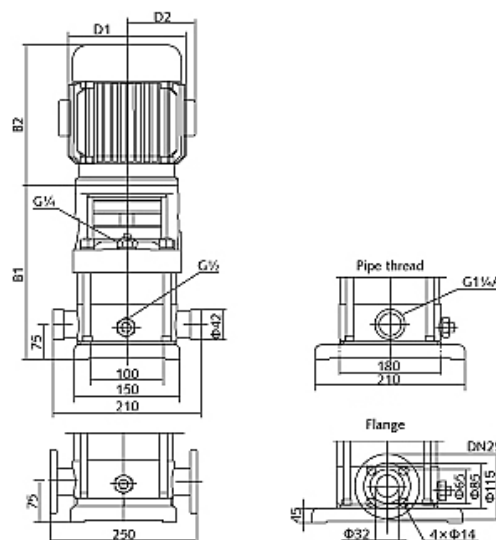

RSV Series Vertical Multistage In Line Pumps

RSV4



Performance Curve

2900 rpm

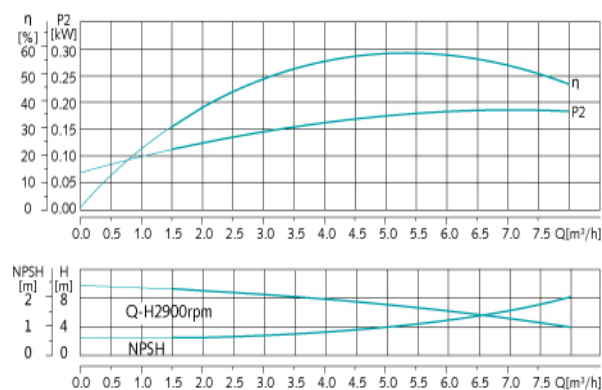
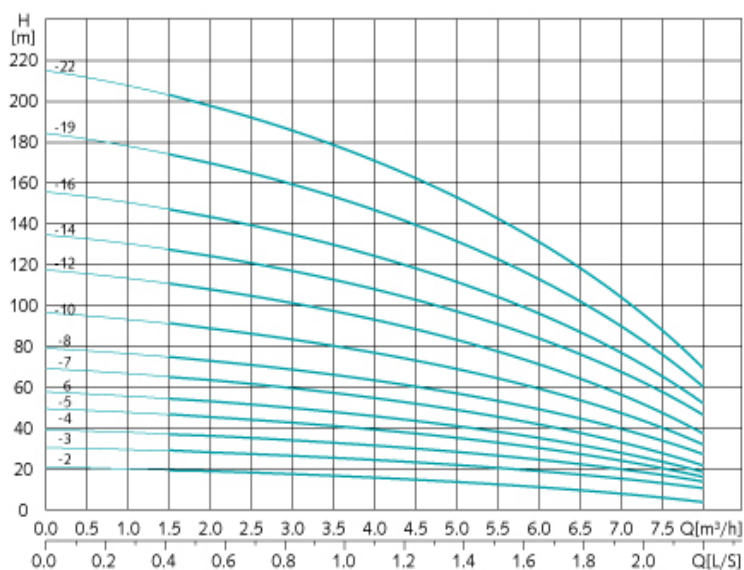

Technical Data

Model	Power (kW)	B 1	B 2	B 1 + B 2	D 1	D 2	N. W. (kg)	G. W. (kg)
RSV4-2	0.37	278	220	498	145	80	28	33
RSV4-3	0.55	305	220	525	145	80	29	34
RSV4-4	0.75	340	255	595	175	145	32	38
RSV4-5	1.1	367	255	622	175	145	35	41
RSV4-6	1.1	394	255	649	175	145	35	41
RSV4-7	1.5	434	265	699	195	155	39	46
RSV4-8	1.5	461	265	726	195	155	40	46
RSV4-10	2.2	515	290	805	195	155	44	50
RSV4-12	2.2	569	290	859	195	155	45	52
RSV4-14	3	632	325	957	215	180	50	57
RSV4-16	3	686	325	1011	215	180	51	58
RSV4-19	4	767	340	1107	240	190	57	65
RSV4-22	4	848	340	1188	240	190	59	67

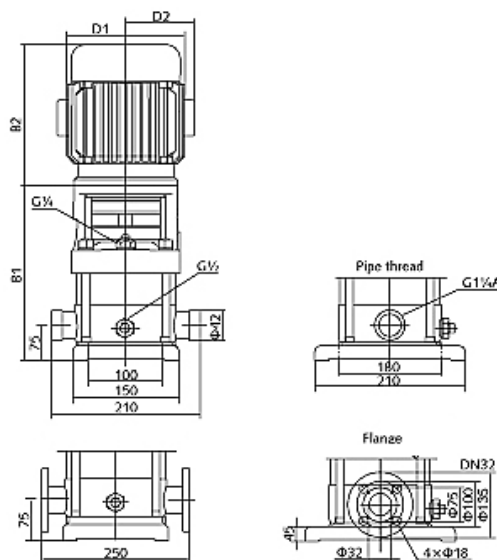

RSV Series Vertical Multistage In Line Pumps

RSV8



Performance Curve

2900 rpm

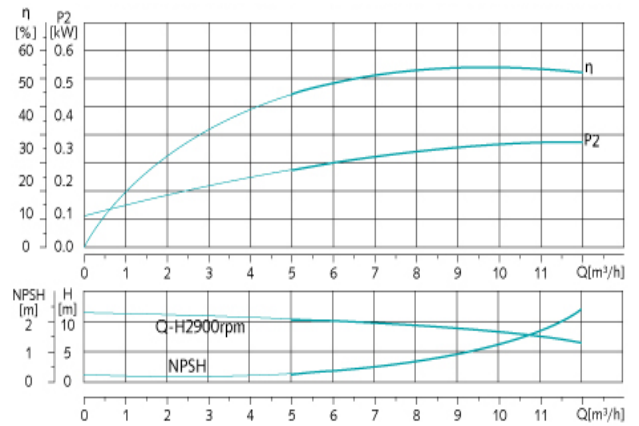
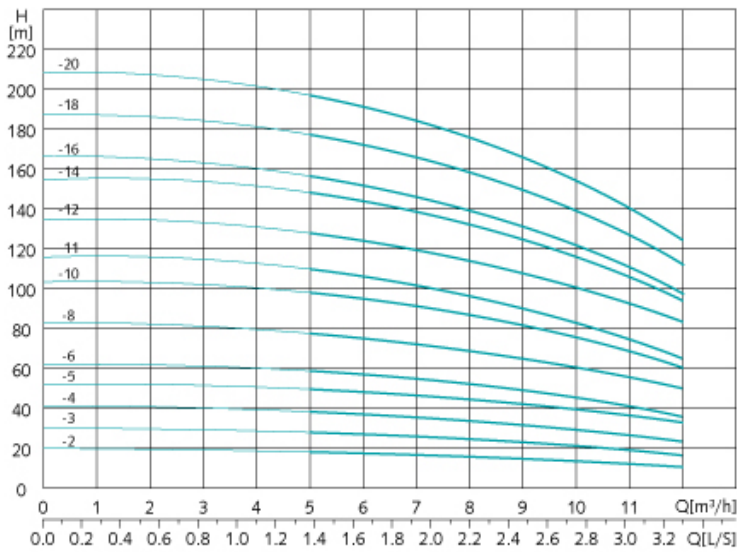

Technical Data

Model	Power (kW)	B1	B2	B1+B2	D1	D2	N.W. (kg)	G.W. (kg)
RSV8-2	0.75	375	255	630	175	145	44	51
RSV8-3	1.1	405	255	660	175	145	47	54
RSV8-4	1.5	440	265	705	195	155	51	58
RSV8-5	2.2	470	290	760	195	155	54	62
RSV8-6	2.2	500	290	790	195	155	56	64
RSV8-8	3	570	325	895	215	180	62	71
RSV8-10	4	630	340	970	240	190	69	79
RSV8-11	4	660	340	1000	240	190	70	80
RSV8-12	5.5	715	390	1105	275	210	89	103
RSV8-14	5.5	774	390	1164	275	210	91	106
RSV8-16	5.5	834	390	1224	275	210	93	109
RSV8-18	7.5	894	390	1284	275	210	100	116
RSV8-20	7.5	954	390	1344	275	210	102	119

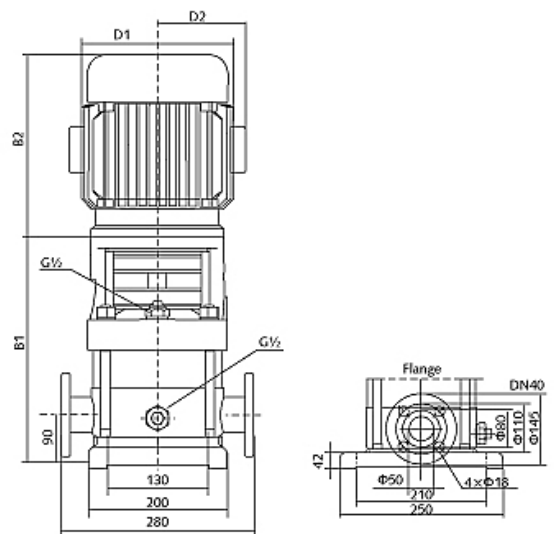

RSV Series Vertical Multistage In Line Pumps

RSV16



Performance Curve

2900 rpm

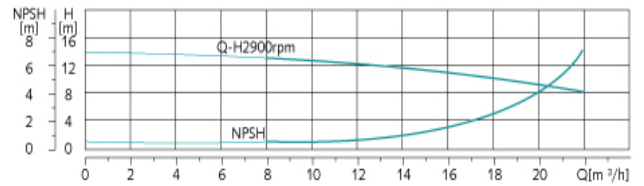
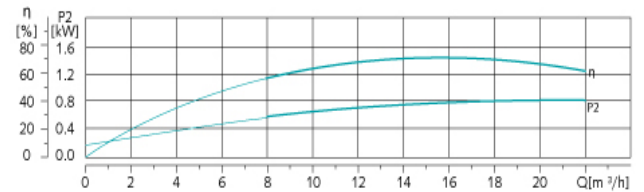
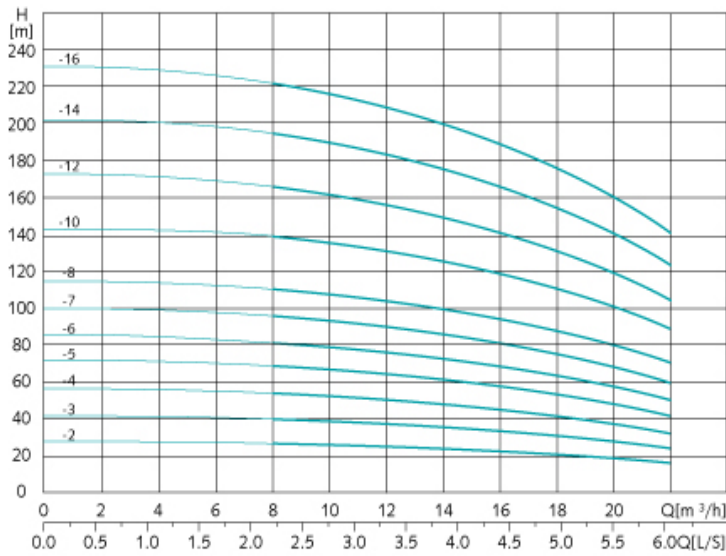

Technical Data

Model	Power (kW)	B1	B2	B1+B2	D1	D2	N.W. (kg)	G.W. (kg)
RSV16-2	2.2	410	290	700	195	155	52	59
RSV16-3	3	465	325	790	215	180	57	65
RSV16-4	4	510	340	850	240	190	63	72
RSV16-5	5.5	581	390	971	275	210	83	96
RSV16-6	5.5	626	390	1016	275	210	84	98
RSV16-7	7.5	671	390	1061	275	210	90	105
RSV16-8	7.5	716	390	1106	275	210	92	107
RSV16-10	11	837	505	1342	330	255	173	190
RSV16-12	11	927	505	1432	330	255	176	194
RSV16-14	15	1017	505	1522	330	255	189	207
RSV16-16	15	1107	505	1612	330	255	192	211

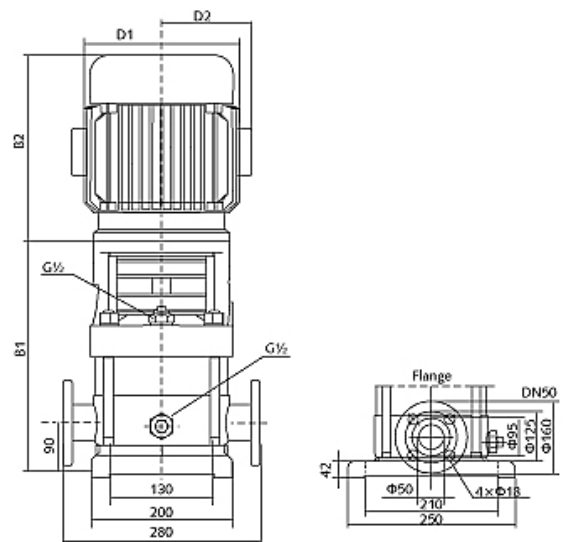

RSV Series Vertical Multistage In Line Pumps

RSV20



Performance Curve

2900 rpm

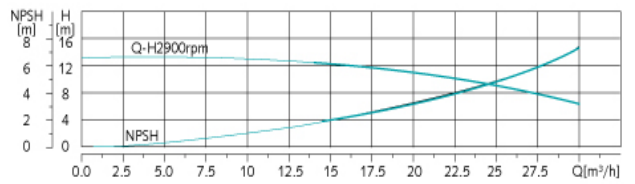
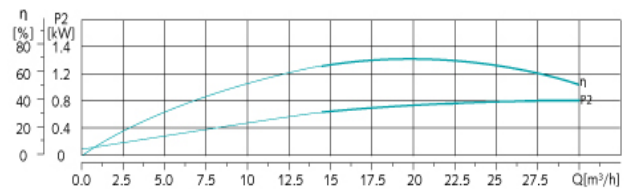
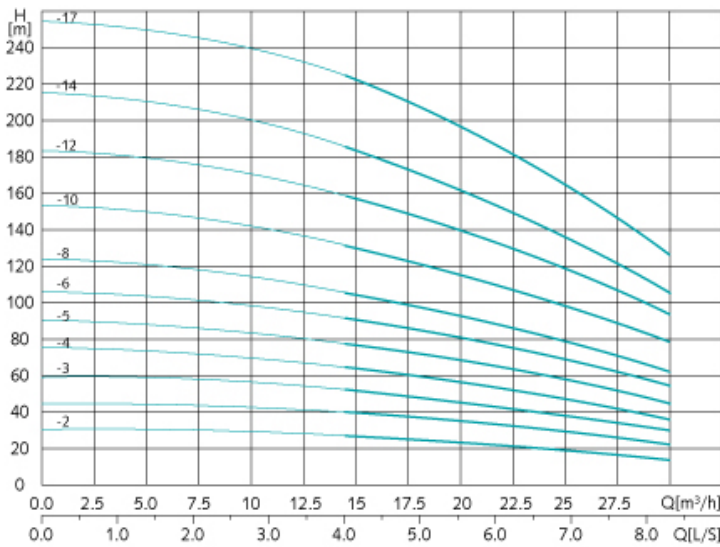

Technical Data

Model	Power (kW)	B1	B2	B1+B2	D1	D2	N.W. (kg)	G.W. (kg)
RSV20-2	2.2	410	290	700	195	155	52	59
RSV20-3	4	465	340	805	240	190	62	70
RSV20-4	5.5	536	390	926	275	210	82	93
RSV20-5	5.5	581	390	971	275	210	83	97
RSV20-6	7.5	626	390	1016	275	210	89	103
RSV20-7	7.5	671	390	1061	275	210	90	105
RSV20-8	11	747	505	1252	330	255	170	185
RSV20-10	11	837	505	1342	330	255	173	190
RSV20-12	15	927	505	1432	330	255	186	204
RSV20-14	15	1017	505	1522	330	255	189	208
RSV20-17	18.5	1152	560	1712	330	255	209	229

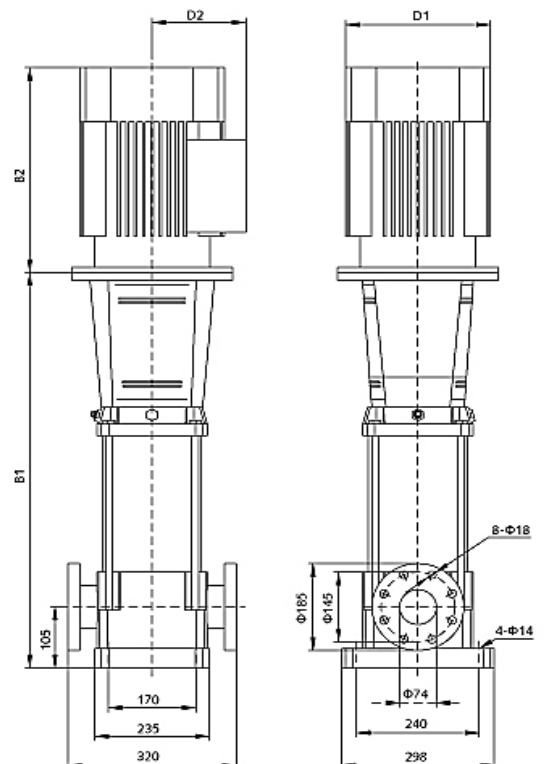

RSV Series Vertical Multistage In Line Pumps

RSV32



Performance Curve

2900 rpm

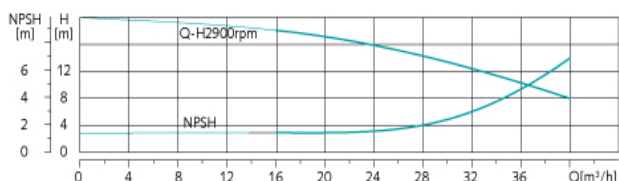
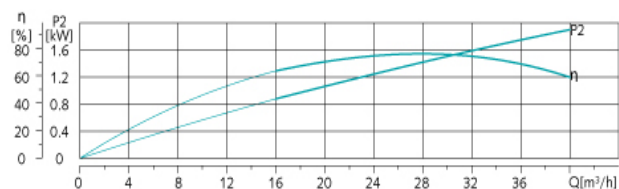
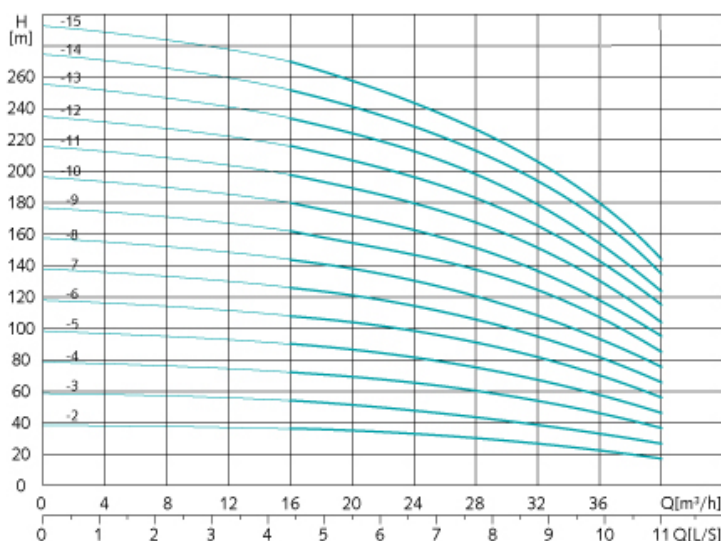

Technical Data

Model	Power (kW)	B1	B2	B1+B2	D1	D2	N.W. (kg)	G.W. (kg)
RSV32-2	4	634	340	974	240	190	72	99
RSV32-3	5.5	724	390	1114	275	210	92	119
RSV32-4	7.5	794	390	1184	275	210	101	128
RSV32-5	11	894	505	1399	330	255	183	216
RSV32-6	11	964	505	1469	330	255	187	220
RSV32-7	15	1034	505	1539	330	255	201	234
RSV32-8	15	1104	505	1609	330	255	205	244
RSV32-9	18.5	1174	560	1734	330	255	224	263
RSV32-10	18.5	1244	560	1804	330	255	228	267
RSV32-11	22	1314	590	1904	380	280	262	305
RSV32-12	22	1384	590	1974	380	280	270	313
RSV32-13	30	1454	660	2114	420	305	331	381
RSV32-14	30	1524	660	2184	420	305	335	385
RSV32-15	30	1594	660	2254	420	305	339	389

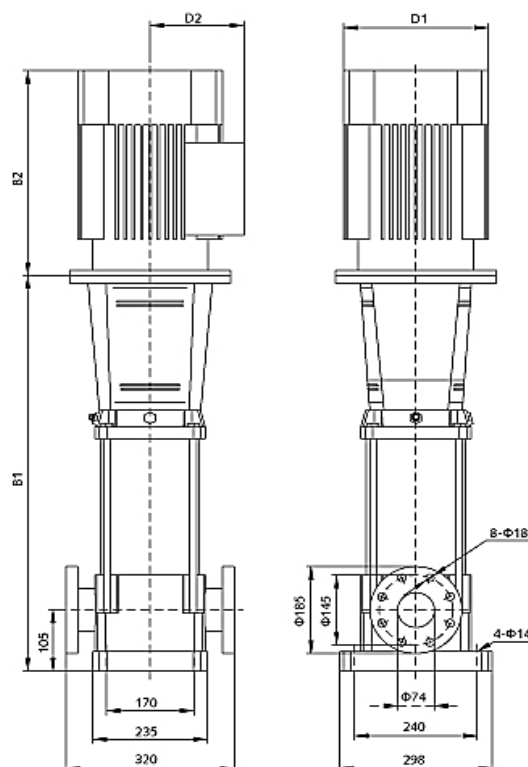

RSV Series Vertical Multistage In Line Pumps

RSV45



Performance Curve

2900 rpm

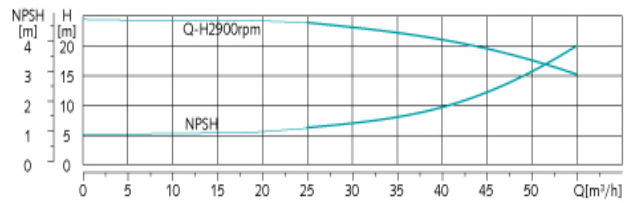
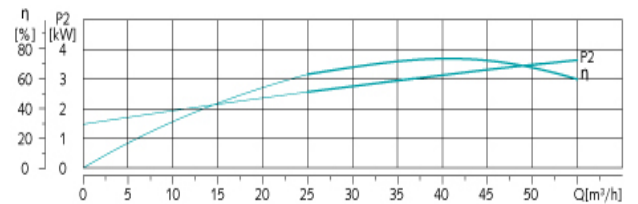
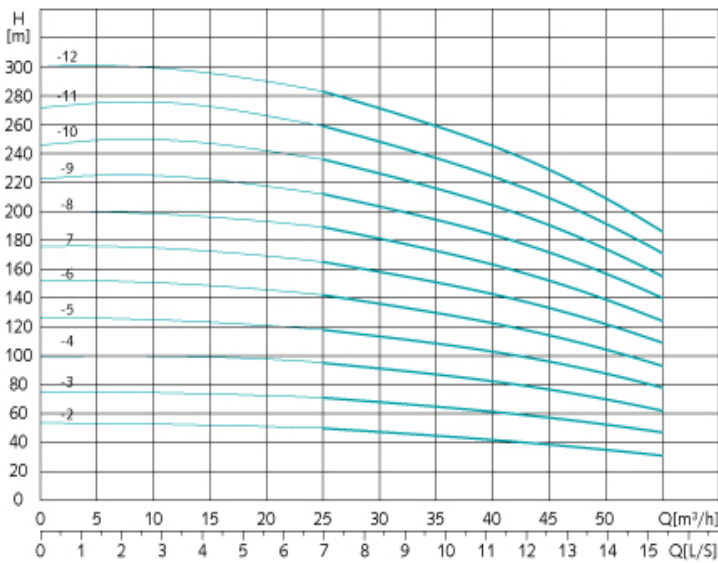

Technical Data

Model	Power (kW)	B1	B2	B1+B2	D1	D2	N.W. (kg)	G.W. (kg)
RSV45-2	7.5	715	390	1105	275	210	106	134
RSV45-3	11	825	505	1330	330	255	188	221
RSV45-4	15	905	505	1410	330	255	202	235
RSV45-5	18.5	985	560	1545	330	255	221	254
RSV45-6	22	1065	590	1655	380	280	256	291
RSV45-7	30	1145	660	1805	420	305	321	365
RSV45-8	30	1225	660	1885	420	305	324	368
RSV45-9	37	1305	660	1965	420	305	340	384
RSV45-10	37	1385	660	2045	420	305	345	396
RSV45-11	45	1465	710	2175	470	335	401	452
RSV45-12	45	1545	710	2255	470	335	405	456

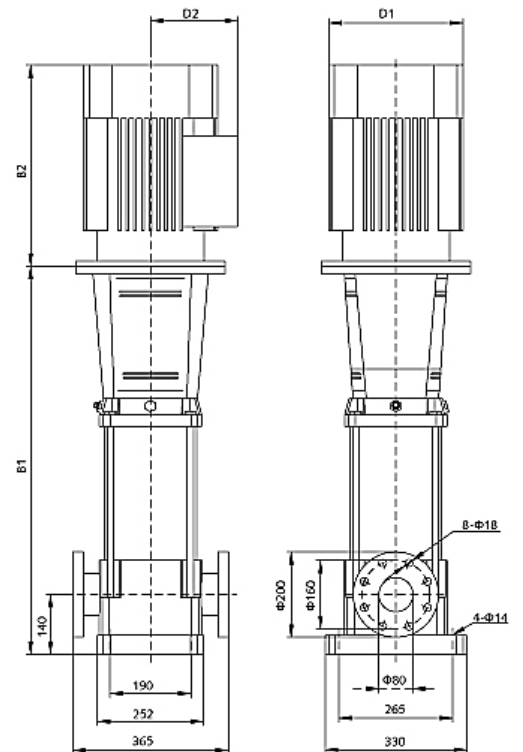

RSV Series Vertical Multistage In Line Pumps

RSV64

Performance Curve

2900 rpm

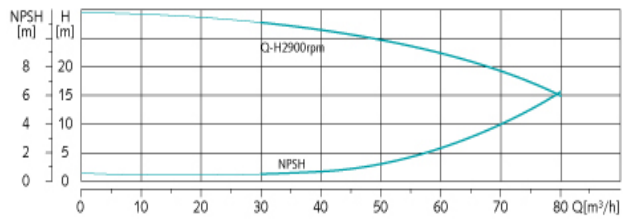
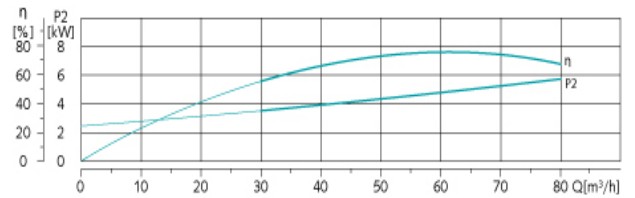
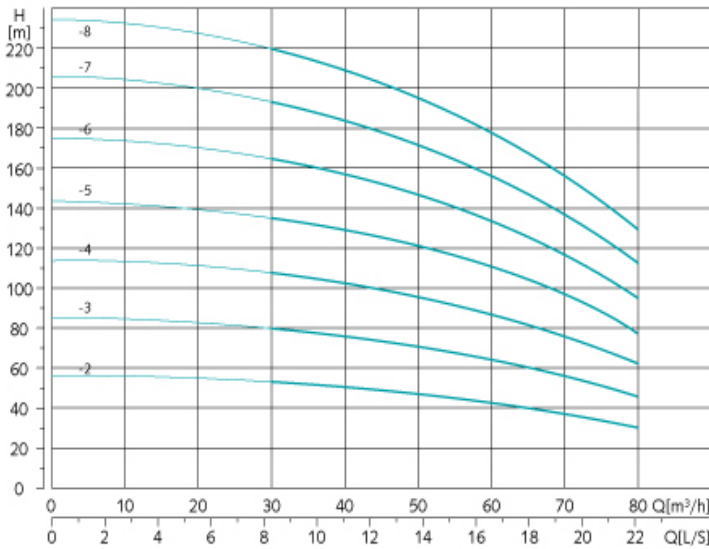

Technical Data

Model	Power (kW)	B1	B2	B1+B2	D1	D2	N.W. (kg)	G.W. (kg)
RSV64-2	11	715	505	1220	330	255	204	232
RSV64-3	18.5	825	560	1385	330	255	233	266
RSV64-4	22	905	590	1495	380	280	268	301
RSV64-5	30	985	660	1645	420	305	333	366
RSV64-6	37	1065	660	1725	420	305	350	385
RSV64-7	45	1145	705	1850	470	335	406	450
RSV64-8	45	1225	705	1930	470	335	410	454

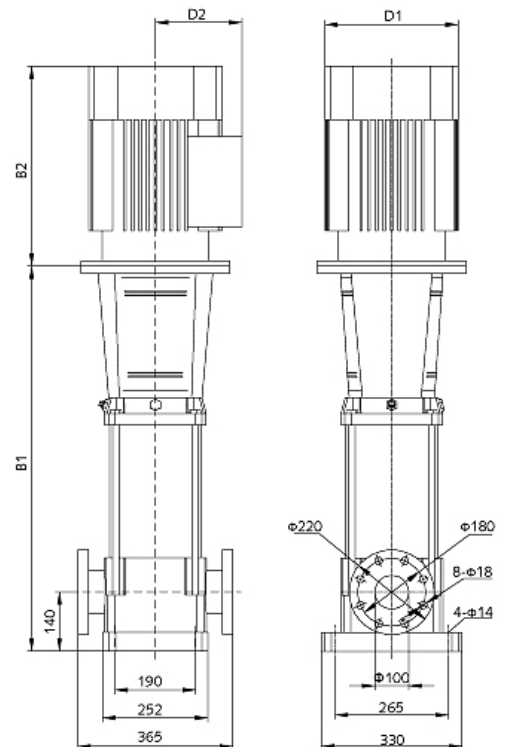

RSV Series

Vertical Multistage In Line Pumps



Electric Motor - Standard Features:

- ❖ Three Phase, 380V ~ 415V 50Hz
- ❖ Dimensions According To IEC-72
- ❖ Performance According To IEC-34
- ❖ IE1 Efficiency
- ❖ IP 55, TEFC
- ❖ Continuous Duty-S1
- ❖ Ambient Temp. 40°C
- ❖ Class "F" Insulation (Class B Temp Raise)
- ❖ Regreasing Nipples Frame Size 160 And Above
- ❖ Thermistors fitted in 160M and Above
- ❖ High Quality Vacuum Pressure Impregnation (VPI) Stator

Electrical Data – IE1

OUTPUT kW P _N	FULL LOAD SPEED, n (rpm)	NO LOAD CURRENT 400V (A)	I _N			EFF η @ 100%FL	COS φ @ 100%FL	I _A I _N	FL TORQUE M _N Nm
			380V (A)	400V (A)	415V (A)				
0.37	2823	0.76	1.00	0.95	0.92	71.0	0.79	4.9	1.3
0.55	2843	0.8	1.4	1.3	1.2	76.0	0.81	5.9	1.8
0.75	2840	0.9	1.8	1.7	1.7	75	0.83	5.5	2.5
1.1	2845	1.2	2.6	2.5	2.4	76.2	0.84	5.5	3.7
1.5	2850	1.4	3.5	3.3	3.2	78.5	0.84	6	5.0
2.2	2850	2	4.9	4.6	4.4	81	0.85	6.1	7.4
3	2860	2.2	6.3	6.0	5.8	82.6	0.87	6.9	10.0
4	2870	2.4	8.2	7.8	7.5	84.2	0.88	6.7	13.3
5.5	2900	3.7	11.1	10.5	10.1	85.7	0.88	7.4	18.1
7.5	2915	4.5	14.9	14.1	13.6	87	0.88	7.6	24.6
11	2930	6.2	21.2	20.2	19.5	88.4	0.89	7.3	35.9
15	2930	7.6	28.6	27.2	26.2	89.4	0.89	7.2	48.9
18.5	2935	8.1	34.7	33.0	31.8	90	0.9	7.3	60.2
22	2940	11	41.0	39.0	37.6	90.5	0.9	7	71.5
30	2950	14.5	55.4	52.6	50.7	91.4	0.9	5.9	97.1
37	2955	17.3	67.9	64.5	62.2	92	0.9	6.5	119.6
45	2960	20.5	82.1	78.0	75.2	92.5	0.9	7.1	145.2

Electrical Data – IE2

OUTPUT kW	FULL LOAD SPEED (rpm)	INL 400V (amps)	IFL 380V (amps)	IFL 400V (amps)	IFL 415V (amps)	EFF η @ 100%FL	COS φ @ 100%FL	IST IFL	FULL LOAD TORQUE N·m
1.1	2860	1.1	2.5	2.3	2.3	79.6	0.85	6.5	3.7
1.5	2850	0.91	3.2	3.0	2.9	81.3	0.88	5.5	5.0
2.2	2855	1.2	4.5	4.2	4.1	83.2	0.9	6.1	7.4
3	2890	1.6	6.0	5.7	5.5	84.6	0.9	7.3	9.9
4	2895	2.4	7.9	7.5	7.2	85.8	0.9	7.1	13.2
5.5	2910	2.6	10.6	10.0	9.7	87	0.91	6.9	18.0
7.5	2910	4.2	14.2	13.5	13.0	88.1	0.91	7.3	24.6
11	2940	5.1	20.5	19.5	18.8	89.4	0.91	7.3	35.7
15	2940	6.8	27.7	26.3	25.4	90.3	0.91	7.3	48.7
18.5	2935	6.9	33.6	31.9	30.8	90.9	0.92	6.8	60.2
22	2945	12.7	40.7	38.6	37.2	91.3	0.9	7.2	71.3
30	2960	14.8	54.4	51.7	49.9	92	0.91	7	96.8
37	2960	19.4	66.8	63.4	61.2	92.5	0.91	7	119.4
45	2970	22.2	81.8	77.7	74.9	92.9	0.9	6.8	144.7

Regent Pumps - RSV-QX Booster Pump System with Integrated Frequency Speed Drive Motor

Regent Pumps booster systems, compact package with easy access to all service parts, all motors are fitted with integrated Frequency Speed Drive to ensure of smooth operation and manages pump performances to match a wide range of system conditions. Booster system is factory assembled and tested, pre-set according to customer requirement

- Electric Motor IE3 efficiency 380V ~ 415V IP55
- Bearing lubrication for life (up to 7.5kW) 11kW and above, bearing re-grease able.
- Frequency Speed Drive – WEG Band
- Stainless Steel SS304 Manifolds with individual isolation valves
- Manifold rated to 16 Bar as Standard (Higher available)
- 18 litre pressure vessel mounted on manifold

System Available

- Duplex System (2 pumps)
- Triplex System (3 pumps)
- Quad System (4 Pumps)

Operating Parameters

- Max Flow – 200m³/h
- Max head – 300m
- Manifold – DN25 to DN200

Benefit

- Energy Saving up to 50%**
Variable speed based on water demand
- Extended life of pump and motor**
Soft start functional to minimise mechanical stress

- Maintains constant pressure**
Regardless of fluctuating demand

Energy consumption curve at varying pump speed

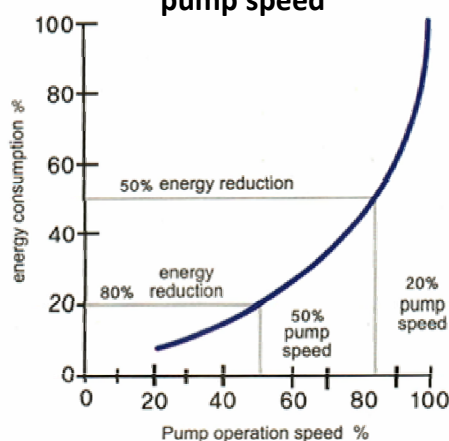

A Generation of Quality Pump Manufacturing

For over 60 years, Regent Pumps has been at the forefront of pump manufacturing in Australia. Over this period, Regent has achieved steady growth and today has become a leading supplier of quality pumps to commercial, industrial and domestic applications, both in Australia and globally. Regent operates a modern manufacturing plant in Melbourne and markets its range of products through an international network of specialist distributors. Manufacture a range of truck and trailer mounted high pressure sewer, drain cleaning machines and mine water dewatering package. The corner stone of Regent's success has been the focus on developing innovative, quality pumping solutions that will stand the test of time at a competitive price.

Head Office / Manufacturing / Warehouse 1 - 7 Redwood Drive, Dingley, Victoria, Australia 3172



Projects and International Division

Regent Asia Pacific Pty. Ltd.

102-104, Malcolm Road, Braeside VIC 3195,

P.O.Box 650 Mordialloc

VIC 3172 Australia

Tel: +61 (0) 3 97726742 / +61 452 045 228

Email: sales@regentap.com.au www.regentap.com.au